

Intelligent Gate Driver

for IGBTs and Power MOSFETs

Description

The intelligent gate drivers of the IGD type series are single-channel drive components designed for IGBTs and power MOSFETs. They were developed specifically for the precise and reliable driving and reliable protection of high-power modules, high-voltage modules, series and parallel circuits.

The drivers IGD608AI/AN and IGD615AI/AN are mutually pin-compatible and differ only in their driver power. Each driver has an integrated DC/DC converter with a power of 6 W. Transmission of the drive information and of the status acknowledgement is electrically isolated. The drivers represent a complete solution and can be used for practically all known converter topologies.



Product Highlights

- ✓ Suitable for IGBTs and power MOSFETs
- ✓ Protect the power transistors
- ✓ Extremely reliable, long service life
- ✓ High gate current of $\pm 8A$ and $\pm 15A$
- ✓ Electrical isolation 4000 Vac
- ✓ Electrically isolated status acknowledgement
- ✓ Monitoring of power supply and self-monitoring
- ✓ Switching frequency DC to MHz
- ✓ Duty cycle: 0... 100%
- ✓ High dv/dt immunity, guaranteed $>50,000V/\mu s$
- ✓ Shorten development time

Applications

- ✓ Inverters
- ✓ Motor drive technology
- ✓ Traction
- ✓ Railroad power supplies
- ✓ Converters
- ✓ Power engineering
- ✓ Switch-mode power supplies
- ✓ Radiology and laser technology
- ✓ DC/DC converter
- ✓ Research
- ✓ RF generators and converters

Important Note

The drivers IGD608AI/AN and IGD615AI/AN are a further development of the tried-and-tested IHD680AI/AN half-bridge drivers. In contrast to the IHD drivers, however, the IGD drivers are single-channel components. Thus the entire 6-W power of the DC/DC converter is available for driving a single (large) power semiconductor. Drivers are available for maximum gate currents of ± 8 A and ± 15 A.

This data sheet lists only those specifications that differ for the IGD drivers of the IHD680AI/AN series. Data sheet IHD215/280/680 lists all other technical data.

The drivers of the IGD series are supplied in the same design as those of the IHD series and are largely pin-compatible with them. However, the drive channel described in the IHD data sheet as channel 1 is not present for the IGD drivers (see terminal assignment and blocking diagram).

The application hints in data sheet IHD215/280/680 also apply to these drivers.

Pin Designation

Pin	Desig.	Function	Pin	Desig.	Function
1	GND	Power supply GND	36	NC	not connected
2	GND	Power supply GND	35	NC	not connected
3	GND	Power supply GND	34	NC	not connected
4	GND	Power supply GND	33	NC	not connected
5		not present	32	NC	not connected
6		not present	31	NC	not connected
7		not present	30	res.	reserved (do not connect!)
8		not present	29		not present
9	GND	Power supply GND	28		not present
10	Vcc	Power supply plus terminal	27		not present
11		not present	26		not present
12		not present	25	G	Gate driver output
13		not present	24	COM	Virtual common
14		not present	23	Cs	Blocking capacitor
15	SO2+	Status output +	22	E	Emitter / Source
16	SO2-	Status output -	21	REF	External reference
17	IN2-	Input inverting	20	Cb	Blocking time capacitor
18	IN2+	Input non-inverting	19	ME	V_{CE} measurement

Legend for terminal assignment:

Pins with the designation "not connected" and "reserved" are physically present but must not be connected to an electrical potential. Pins with the designation "not present" are not physically present.

Block and Connection Diagram

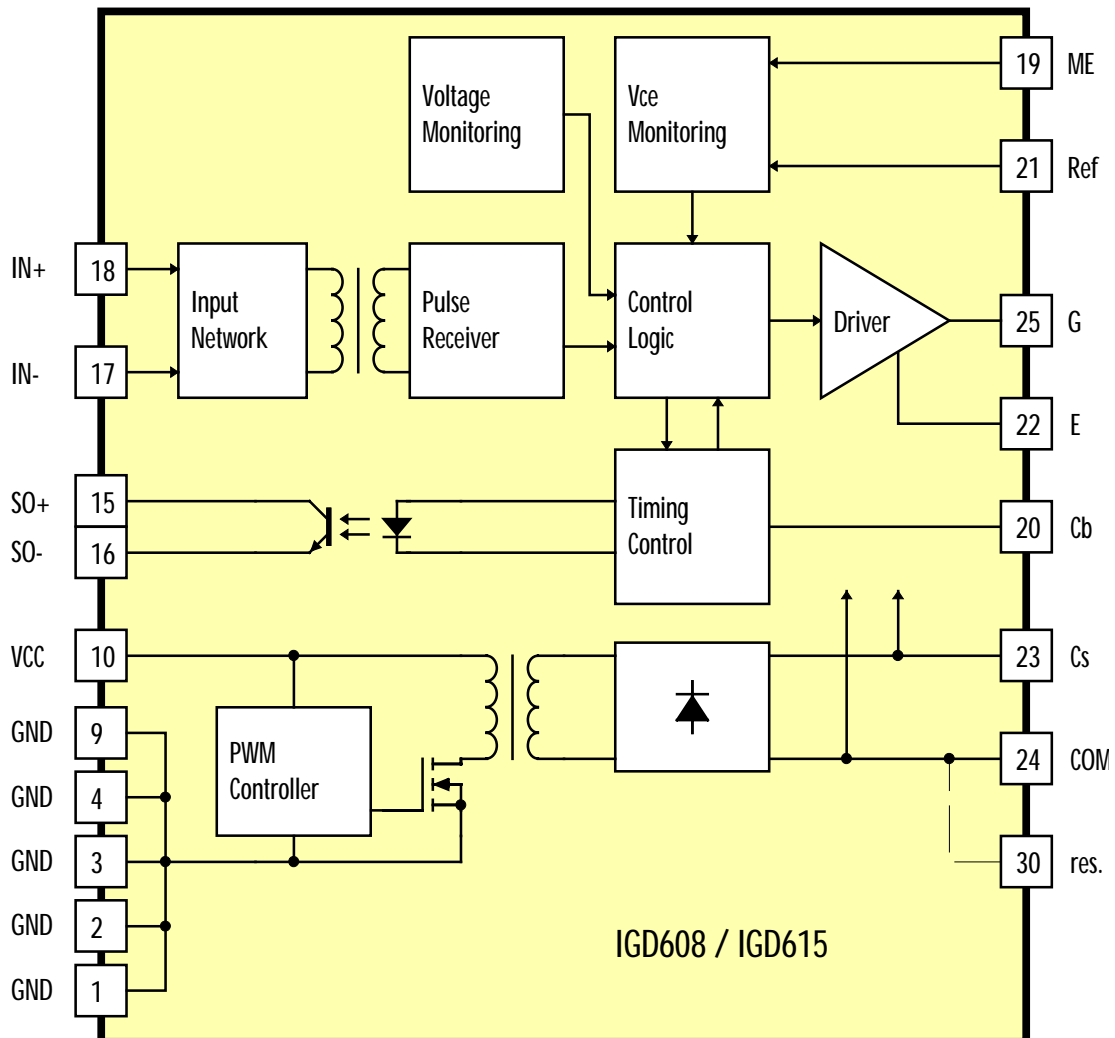

Electrical Characteristics

Parameter	Typ	min	typ	max	units
MTBF	all types		>2'500'000		hours
Maximum output current I_{out}	IGD608xx	-8		+8	Adc
	IGD615xx	-15		+15	Adc
Supply current I_{cc}	all types, without load		60		mA
Max. supply current I_{cc}	all types, with maximal load			450	mA
Output power DC/DC converter	all types (see Note 3 & 11)			6	W
Efficiency η	internal DC/DC converter		85		%

All data refer to +25°C and $V_{cc} = 15V$ unless otherwise specified

Ordering Information

Drivers for $\pm 8A$ gate current

Standard version (0...70°C)	IGD 608 EN
Industry version (-40...+85°C)	IGD 608 EI

Drivers for $\pm 15A$ gate current

Standard version (0...70°C)	IGD 615 EN
Industry version (-40...+85°C)	IGD 615 EI

Other Products and Informations

Drivers for higher isolation voltages (i.e. railroad applications)

Please request further information

Other intelligent drivers (i.e. halfbridge drivers etc.)

Please ask for an "overview of intelligent drivers"

Evaluation boards

Please ask for an "overview of evaluation boards"

Manufacturer

Your Distribution Partner

CT-Concept Technology Ltd.
 Intelligent Power Electronics
 Hauptstrasse 3
 CH-2533 Leubringen / Evilard
 (Switzerland)

Tel ++41 (0)32 / 322 42 36
 Fax ++41 (0)32 / 322 22 51

© Copyright 1992...1996 by CT-Concept Technology Ltd. - Switzerland.
 We reserve the right to make any technical modifications without prior notice.

All rights reserved.
 IGD5xE02 07/96